



WHITE KNIGHT®
.....engineer approved

PPMC300 MINI PUMP

Mini Pump for Low Flow Applications

Mini pumps feature PTFE/PFA fluid paths for high-purity chemical processes. They are capable of up to 300 ml/min flow rates and 160 psi discharge pressures.

Features & Benefits

- Metal-free, PTFE/PFA flow path
- 300 ml/min max flow rate
- 160 psi max discharge pressure
- 100 psi max air supply pressure
- 0.5 m (20 in) suction lift
- Dry-run capable
- Safe, leak-free operation
- Mount in any direction
- Various liquid connection options
- Operates with analog or digital external inputs, or fixed cycle rate internal controls
- 24 VDC using 5 pin Turck power and input connections

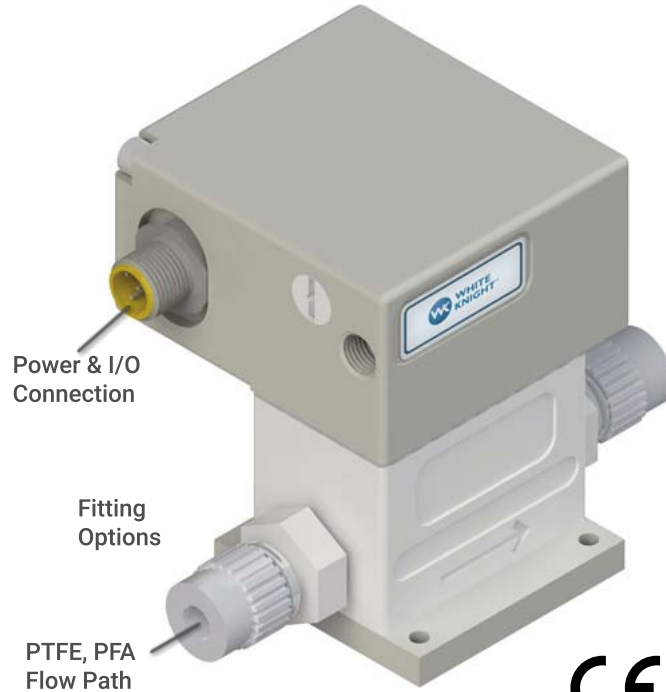

Flow Rate
≤ 300 ml/min

Fluid Pressure
≤ 11 Bar (160 psi)

Air Pressure
≤ 7 Bar (100 psi)

Temperature
≤ 100°C (212°F)

Shift Method
On-board controller with internal solenoid valves

Industries
Semiconductor
LEDs & Electronics
Flat-Panel Displays
Photovoltaic / Solar

Applications
Chemical replenishing, mixing, blending, dosing, and spiking; photoresist, etch and clean processes



Operation

Mini pumps operate by two solenoid valves that actuate both the suction and dispense actions of the pump. While spring-loaded checks enable the pump to mount in any direction, an upward flow path is preferred to better evacuate air bubbles from the fluid line and to improve repeatability.

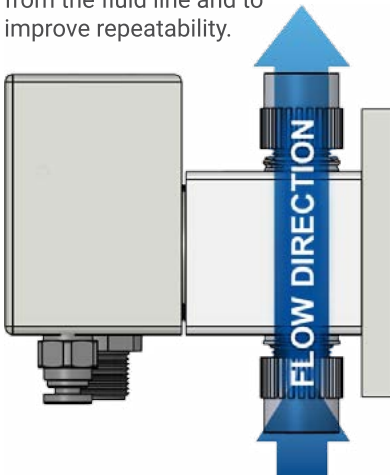

Pin	Function	Connection Type	Connector Diagram
1	Power	24 VDC Power Supply	<p>5 pin Turck EuroFast style connector</p>
2	Analog Input	0-5 VDC Analog input to set cycle rate. - 0-1 VDC = Pump Off - 1-5 VDC = Pump On = 0-400 CPM	
3	Common Ground	0 VDC Ground	
4	Valve Control Actuate Suction	Sink Type Signal - 24 VDC = Not Active - 0 VDC = Active	
5	Valve Control Actuate Discharge	Sink Type Signal - 24 VDC = Not Active - 0 VDC = Active	

Operation Mode	Description	Notes
Analog Input	Pump will stop cycling if analog input is 1 VDC or less. If analog input is 1-5 VDC, cycle rate equals: 100*Voltage-100	Pump should be powered on and valve controls disconnected.
External Valve Control	When pump is powered on and analog input is less than 1 VDC, solenoids and cycle rate can be controlled from external PLC.	Pump should be powered on.
Fixed Cycle Rate * By request only	Pump cycles at desired rate when on. It continues cycling until powered off.	Pump should be powered on and valve controls disconnected.

www.pkm-konrad.ch

+41 32 751 64 44





WHITE KNIGHT®

.....engineer approved

PPMC300 Mini Pump

Performance

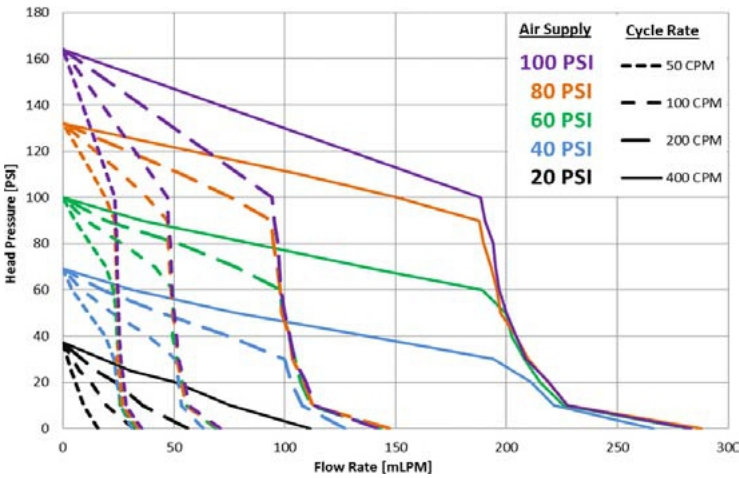

Temperature Limitations

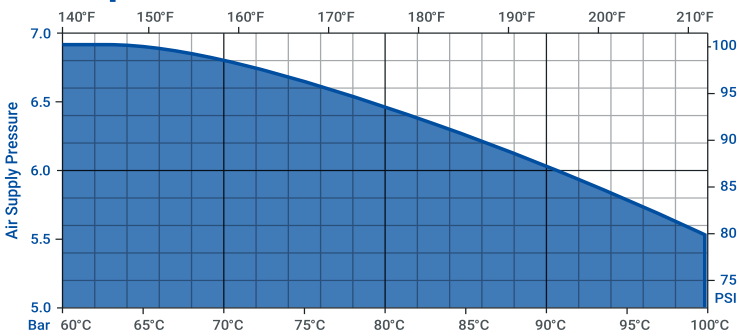

Dimensions

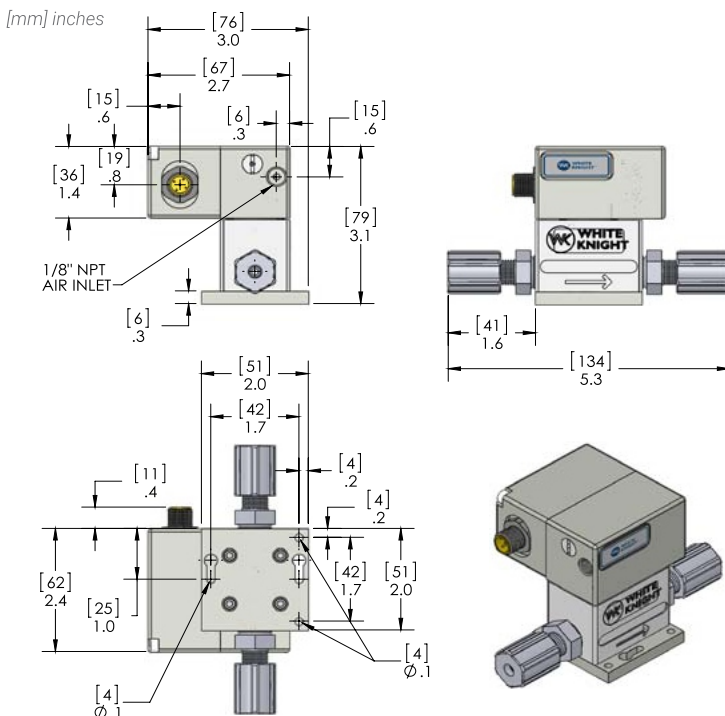

Specifications

Model	PPMC300
Dispense Volume per Stroke	~0.75 ml*
Max Flow	≤ 300 ml/min
Max Fluid Pressure	≤ 11 Bar (160 psi)
Max Air Pressure	≤ 7 Bar (100 psi)
Cycles per min	400 max
Air Consumption	1 SCFM
Fluid Path Materials	PTFE, PFA
Max Dry Suction Lift	≤ 508 mm (20 in)
Solenoid Valves	2x 24V Manifold Valves 0.7 CV
Turck Connector	5 Pin O-ring Sealed
On-Board Controller	Power: 24 VDC Max Power Consumption: 6 Watts Internal I/O: • Two 24 VDC Valve outputs External I/O: • One 0-5 VDC analog input. • Two NPN Compatible Signal Input

* Stroke length varies depending on operation.

Configuration

PPMC 300 CD - F 04 E3 - C1 - 001



- ① **Pump Type**
PPMC = Mini Pump
- ① **Pump Size**
300 = 300 ml/min max discharge
- ② **Liquid Valve Type**
CD = Spring-loaded disk valves
- ③ **Fitting Style**
F = Flaretek® compatible
P = Pillar S-300®
* F not available in 1/8 in.
- ④ **Fitting Size**
02 = 1/8 in
04 = 1/4 in
06 = 3/8 in
- ⑤ **Electrical Connection**
E1 = 15 ft PVC Jacketed Cable
E3 = Turck Connector
E4 = Turck Connector with Cable
- ⑥ **Cycle Rate Control** (optional)
C1 = Communication Based/Potentiometer
C2* = Hard Programmed (*Requires option 7)
- ⑦ **Cycle Rate** (*Used with option 6 C2 Only)
001 = 1 cycle per minute
400 = 400 cycles per minute
(*Enter value between 001 and 400)

Distributor:
PKM Konrad
www.pkm-konrad.ch
 ☎ +41 32 751 64 44

